

Model: LV600HH

# levoit

Hybrid Ultrasonic Humidifier

## Questions or Concerns?

Please contact us Mon-Fri 9:00AM-5:00PM PST  
at (888)726-8520 or email [support@levoit.com](mailto:support@levoit.com)



## Thank You.

Thank you for purchasing the Hybrid Ultrasonic Humidifier by Levoit. We are dedicated to providing you with quality products so that you can see a better you. Should you have any questions or concerns about using your new product, feel free to reach out to our helpful customer support team at (888)-726-8520 or by email at [support@levoit.com](mailto:support@levoit.com). We hope you enjoy your new product!



## Table of Contents

Safety Information	3
Main Functions	4
Set-Up	6
Operation	7
Care & Maintenance	10
Troubleshooting	13
Specifications	14
Customer Support	15
Warranty Information	16



## Safety Information

**IMPORTANT:** Please read, understand, and comply with all of the instructions provided in this manual before using the device. Failure to comply with the instructions given in this manual and/or using the device in ways other than the ones mentioned in this manual may result in serious injury and/or damage to the product.

- Ensure that the plug fits properly into a polarized power socket.
- Always disconnect from a power source by pulling the plug when not in use.
- **DO NOT** use this product in wet environments.
- **DO NOT** use your hand or any other object to cover the nozzle while the unit is on. Doing so may damage the product or cause injury.
- **DO NOT** clean the unit while it is connected to a power source or while it is on.
- Remove the water tank from the base before moving the humidifier.
- **DO NOT** clean the device right after turning it off, especially after it has been diffusing warm mist. Allow the humidifier to completely cool down before cleaning.
- **DO NOT** place the humidifier near sources of heat, such as stove tops, ovens, radiators or computers.
- **DO NOT** place the humidifier near any large pieces of furniture or in any high-traffic area where it can be easily knocked over.
- Unplug the unit when not in use, or while cleaning it out.
- **DO NOT** use cleaning detergents to clean the humidifier; only use distilled white vinegar.
- **DO NOT** plug in the unit with wet hands.
- **DO NOT** place foreign objects into the unit's base or water tank. Do not use other items as replacement parts for this product.
- Keep the machine out of reach from children.
- Only use this humidifier as described in this manual.
- Contact customer service if the unit is damaged or if it is not functioning properly.



## Main Functions

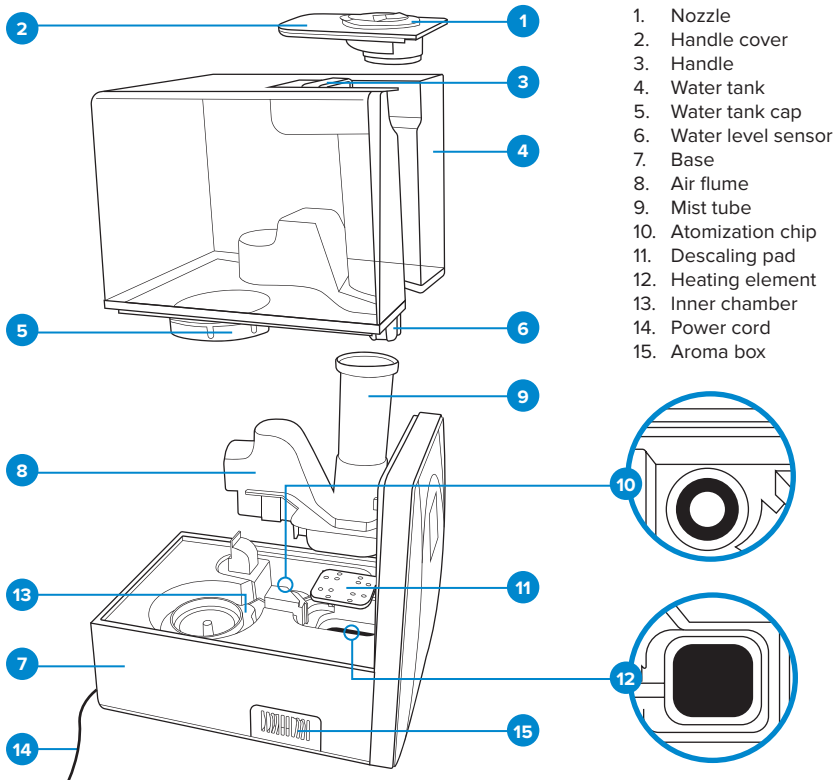

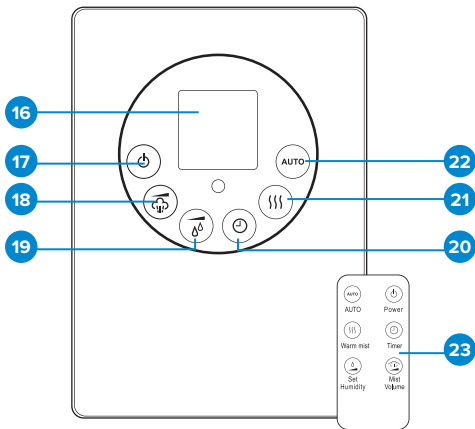

16. LED display
17. On/Off button
18. Mist level button
19. Humidity level button
20. Timer button
21. Warm mist button
22. AUTO button
23. Remote control

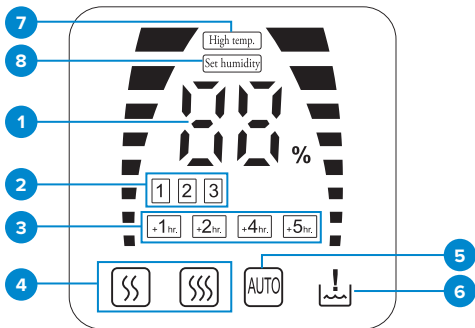

1. Relative humidity (RH) level indicator
2. Cool mist humidity level
3. Timer setting
4. Warm mist humidity level
5. AUTO mode indicator
6. Low water level
7. High temperature warning
8. Set humidity function



## Set-Up

1. Remove the handle cover and set aside. Carefully lift the handle to remove water tank from the base.

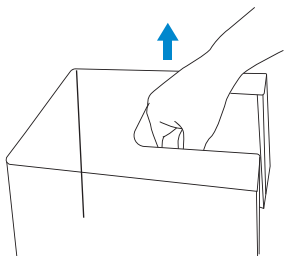
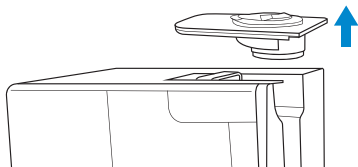

2. Flip the tank over and unscrew the water tank cap.

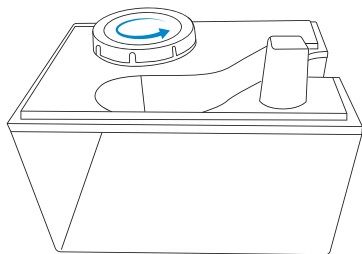

3. Fill the tank with at least 2 cups (480 mL) of cold or room temperature water. Replace the cap once you have filled the tank to your desired level.

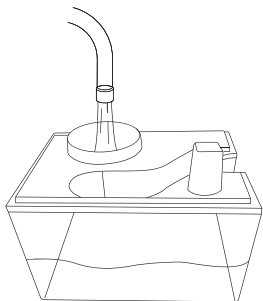

**NOTE:**

- **DO NOT** add water through the mist tube, doing so will damage the device.
- Only fill the water tank with cold or room temperature water.



- Carefully place water tank back onto the base, making sure that the tank is properly aligned. Replace the handle cover.
- Plug the humidifier into an electrical outlet. The unit will chime indicating it is in standby mode.

### Tips

- If the relative humidity in your room exceed 68%RH, it is recommended to use Low mist level or turn the device off for your health.
- It is recommended to adjust the setting based on your room's relative humidity, room size and indoor temperature.



## Operation

### Button Controls

**NOTE:** For added convenience, the same button controls can be found on the included remote control.



Turn on or turn off the humidifier.



Press to cycle through the humidifier's 3 cool mist settings.

- 1:Low mist setting
- 2:Medium mist setting
- 3:High mist setting

**NOTE:** The default setting when you first turn on the humidifier is the medium cool mist setting.



Use the humidity level button to program the humidifier to work toward a set humidity level.

1. Press the humidity level button once to activate this function; keep pressing the humidity level button to select your desired humidity level (the device can be programmed from 40-80% RH).
2. Once you have selected your desired humidity, the display will flash 5 times confirming your selection.
3. The device will start producing mist and will automatically stop operating once the programmed humidity level has been reached.
4. To cancel this function, press the humidity level button until the screen flashes "--".

**NOTE:**

- The programmed humidity level can be changed at anytime by pressing the humidity level button.
- When the programmed humidity level is reached, the RH level indicator will continue to count up for about 2 minutes. This is due to the device sensing the relative humidity in the surrounding.











Press the timer button to set the timer anywhere from 1 to 12 hours. When you have selected your desired time, the display will flash three times before the time is set. The device will automatically turn off when the timer is finished counting down. To cancel or turn off the timer, keep pressing the timer button until the display flashes "C."



Press the warm mist button to have the humidifier generate a gentle stream of warm mist for your living space.

While using this function, the humidifier heats the water before diffusing it into the air, killing any waterborne bacteria or germs. The settings for the warm mist function are noted below:

-  Low setting, press  once.
-  Medium setting, press  twice.
-   High setting, press  three times.
- Off, press  four times.

**NOTE:**

- Use caution when setting the warm mist function, the mist being diffused is hot.
- The warm mist function can be used while the humidifier is on AUTO mode, Humidity level mode, Mist level mode.



Press the AUTO button to activate the automatic humidifying mode. The humidifier will set itself to diffuse warm or cool mist based on the surrounding environment and will maintain environmental humidity from 55-68% RH.

**NOTE:**

- The default function for AUTO mode is cool mist.
- Changing the mist level while on AUTO mode will cancel the AUTO mode function.
- The timer can be set while the device is on AUTO mode.



The low water level icon will appear on the display when more water needs to be added to the water tank. When this happens, the

humidifier will automatically shut off and will turn back on once a sufficient amount of water has been added. The minimum amount of water needed for the humidifier to function is 2 cups (480 mL).



## Care & Maintenance

Make sure the humidifier is disconnected from any power source before cleaning.

1. Unplug the humidifier. Allow the device and any remaining water to completely cool before cleaning.
2. Remove the water tank from the base and pour out any excess water.
3. Remove the air flume and mist tube. Detach the mist tube from the air flume by twisting the tube counterclockwise. Rinse both parts in clean water and dry thoroughly.
4. Remove the descaling pad inside of the heating element and rinse under clean water. Dry the pad with a clean, dry cloth.

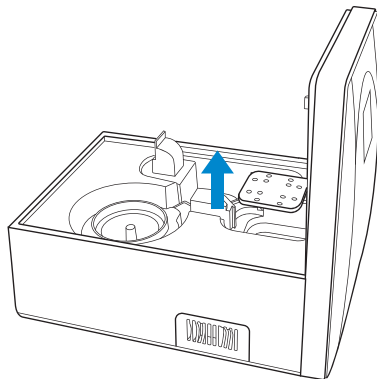
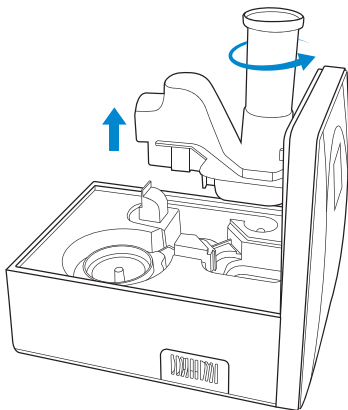

5. Add 1 cup of distilled white vinegar to the inner chamber. Make sure there is vinegar on each section of the chamber including the transducer and heating element. Allow the vinegar to soak for 20-30 minutes.

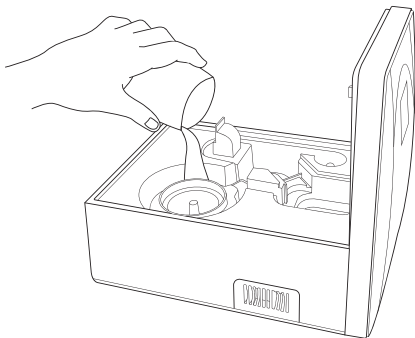

6. While the vinegar is soaking in the chamber, scrub all parts of the inner chamber with a soft brush or sponge to remove any scale or buildup.
7. Pour out the excess vinegar and rinse the inner chamber thoroughly with warm water. Dry the chamber with a soft, clean cloth.

8. To remove any scale or buildup in the water tank, pour 3 cups of distilled white vinegar along with 3 cups of water. Evenly coat all sides of the water tank with the solution and allow it to soak for 20-30 minutes. Scrub off any remaining buildup with a soft-bristled brush and discard the excess vinegar.
9. Rinse out the water tank with warm water and dry thoroughly with a soft, clean cloth.
10. Allow all parts to dry completely dry. Reassemble the humidifier and store it in a covered space.

## Cleaning the Aroma Pad

1. To clean the aroma pad, remove it from the aroma box and rinse under warm water.

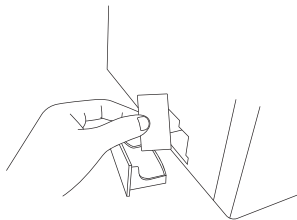

2. Dry the pad with a clean cloth and place it back into the aroma box.

## Replacing the Remote Control Battery

1. Press the locking tab toward the pulling slot to remove the battery compartment.

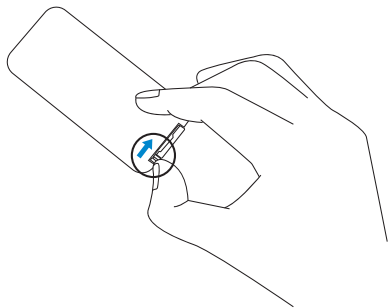

2. Properly dispose of the old battery.
3. Place a new CR2025 3V battery into the battery compartment with the positive side facing up.



4. Replace the battery compartment into the remote.

**NOTE:** The remote-controlled distance is about 5m.



## Troubleshooting

Problem	Cause	Solution
No mist is being produced.	Plug not connected to power source.	Connect plug to a power source.
	Device is not turned on.	Turn on the device.
	No water in water tank.	Add water to water tank.
	Water level is too low.	Add at least 2 cups (480 mL) of water to water tank.
Mist has a peculiar odor.	Device is new.	Remove water tank cover and place the water tank in a cool, dry place for 12 hours.
	Water is dirty or has been sitting in tank for a long period of time.	Clean water tank as mentioned in the Cleaning & Maintenance section. Refill the tank with clean water.
Device is making a strange noise.	Water tank is incorrectly positioned.	Properly align the water tank with the base.
	Water level is too low.	Add at least 2 cups (480 mL) of water to water tank.
	Device is on an uneven surface.	Place the device on a flat, even surface.
Mist coming out from base.	Water tank is incorrectly positioned.	Properly align the water tank with the base.
High Temp. warning	Broken water level sensor.	Contact customer service.
	Water has been incorrectly added to the device.	Pour out water in the inner chamber and add water through the water tank.



## Specifications

Voltage :	AC 120V 60Hz
Rated Power :	280W
Effective Range:	285.3 ft <sup>2</sup> (24 m <sup>2</sup> )
Water Tank Capacity:	1.5 gal. (6 L)
Max Cool Mist Capacity:	300 mL/h
Max Warm Mist Capacity:	500 mL/h

## Package Contents

- 1 x Hybrid Ultrasonic Humidifier
- 1 x Remote control
- 2 x Aroma pads
- 1 x Cleaning brush
- 1 x User manual





## Customer Support

Should you encounter any issues or have any questions regarding your new product, feel free to contact our helpful Customer Support Team.

We're here for you.

### **Levoit Corporation**

1202 N. Miller Street, Suite A  
Anaheim, CA 92806

**Toll-Free:** 888.726.8520  
**Email:** [support@levoit.com](mailto:support@levoit.com)

Support Hours  
Monday - Friday: 9:00am - 5:00pm PST

*\*Please have your order number ready before contacting customer support.*



## Warranty Information

### Terms & Policy

Levoit warrants all products to be of the highest quality in material, craftsmanship and service for a minimum of 1 year, effective from the date of purchase.

Warranty lengths may vary between product categories. For specific warranty terms, please refer to your product's listing page. Under the limited warranty, Levoit will replace any product found to be defective due to manufacturer flaws based on eligibility; refunds are available within the first 30 days of purchase. This warranty extends only to personal use and does not extend to any product that has been used for commercial, rental, or any other use in which the product is not intended for. There are no warranties other than the warranties expressly set forth with each product.

This warranty is non-transferrable. Levoit is not responsible in any way for any damages, losses or inconveniences caused by equipment failure or by user negligence, abuse, or use noncompliant with the user manual or any additional safety, use, or warnings included in the

product packaging and manual. This warranty does not apply to the following:

- Damage due to abuse, accident, alteration, misuse, tampering or vandalism.
- Improper or inadequate maintenance.
- Damage in return transit.
- Unsupervised use by children under 18 years of age.

Levoit and its subsidiaries assume no liability for damage caused by the use of the product other than for its intended use or as instructed in the user manual. Some states do not allow this exclusion or limitation of incidental or consequential losses so the foregoing disclaimer may not apply to you. This warranty gives you specific legal rights and you may also have other rights which may vary from state to state.

**ALL EXPRESSED AND IMPLIED WARRANTIES, INCLUDING THE WARRANTY OF MERCHANTABILITY, ARE LIMITED TO THE PERIOD OF THE LIMITED WARRANTY.**

Should your product prove defective within the specified warranty period, please return the defective unit in its original packaging with (1) an original copy of the invoice, (2) your order confirmation number, (3) and your warranty ID number.

To find out more about extending your warranty, visit [www.levoit.com/warranty](http://www.levoit.com/warranty) or contact customer support.

Date of Purchase:

---

Purchased From:

---

Order Number:

---



[www.levoit.com](http://www.levoit.com)